

VECTASAFE® ROUND ANCHOR POST



STANDARD
EN 795
Class A1

Ref.: VP01

Example of assembly:

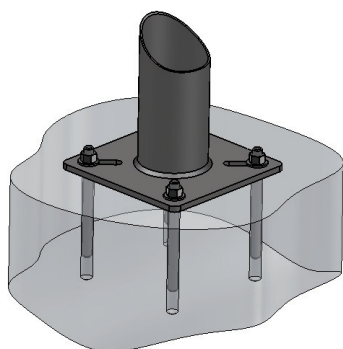

Associated product(s):

- Galvanised clamping back-plate VE02.
- Square anchor post also available Ref.: VP02.

Advantages:

- Economical.
- Quick installation.
- Adjustable fixing thanks to the holes, adaptable on many supports.
- Leak tight flange integrated to the post.
- Product available in round or square tube.

Use (see Assembly and use instructions NT002):

VECTASAFE® anchor post ensures an individual protection against falls from height. This post is an economical solution and it is quick to install.

Technical features:

- Material: steel S235JR.
- Coating: galvanised.
- Weight: 5.5 kg.
- Maximum load: 1000 daN.
- Field of use: inside / outside.
- Complies with the standard EN 795 Class A1.

Assembly instructions (see Assembly and use instructions NT002):

- The post can be installed in any orientation.
- The holes allow an adaptable fixing on many supports.
- Fastenings: 4 M12, center-to-center distance: from 100 to 150 mm.
- It should be fixed in concrete C20/C25 with chemical plugs type HILTI HVU M12, SPIT, WURTH or equivalent, by clamping with post clamping back-plate kit VECTASAFE® Ref.: VE02 + VF02.

Product sizes:

